

Duza imersie pentru injectie directa

LA CEREREA CLIENTULUI

Noua duza de imersie **S4630/Ø** de la WEMA este recomandat pentru injectare directa. Aceasta duza este utilizat de obicei la productia pieselor cu suprafete mari, de exemplu bare de protectie.

Caracteristici:

- Duza de imersie cu rezistenta spiralata incorporata.
- Profil de temperatura uniforma, datorita spiralarii logaritmice a rezistentei.
- Sistem sigilat, autonom
- Imersione fara probleme in matrita, datorita diametrului exterior de numai 46 mm.
- Cablu de conectare cu izolatie PTFE, cu conductor de impamantare si manson metalic impletit.
- Injectarea directa elimina piesa angust.

Specificatii comanda:

n: Cantitatea
Nr.: **S4630**

D: Diametrul gaurii de injectare
I1: Lungime duza calda (**100 - 370 mm**)
A: Unghi de intrare
C: Diametrul de centrare a cilindrului
G: Diametrul filetului
L: Lungimea filetului, inclusiv lungimea de centrare
N: Diametrul de intrare a cilindrului
Z1: Lungimea cilindrica
Z2: Lungimea centrare
R: Raza
SW: Latimea dintre partile plate

Dipping Nozzle for Direct Gating

CUSTOM MADE

The new Dipping Nozzle **S4630/Ø** from WEMA is recommended for direct gating. This nozzle is preferably applied for producing of large-area parts like bumpers.

Features:

- Dipping nozzle with integrated coil heater.
- Uniform temperature profil by means of logarithmic winding.
- Self-contained, plastics sealed system.
- Trouble free immersion of nozzle into mould because of only 46mm shaft diameter.
- PTFE insulated connection cable with ground conductor and metal braided sleeve.
- Direct gating eliminates sprue.

Order specifications:

n: Quantity
No.: **S4630**

D: Gating diameter
I1: Heated nozzle length (**100 - 370 mm**)
A: Entrance angle
C: Barrel centering diameter
G: Barrel thread diameter
L: Thread length, incl. centering
N: Barrel entrance diameter
Z1: Cylindrical length
Z2: Centering length
R: Tip radius
SW: Width between flats

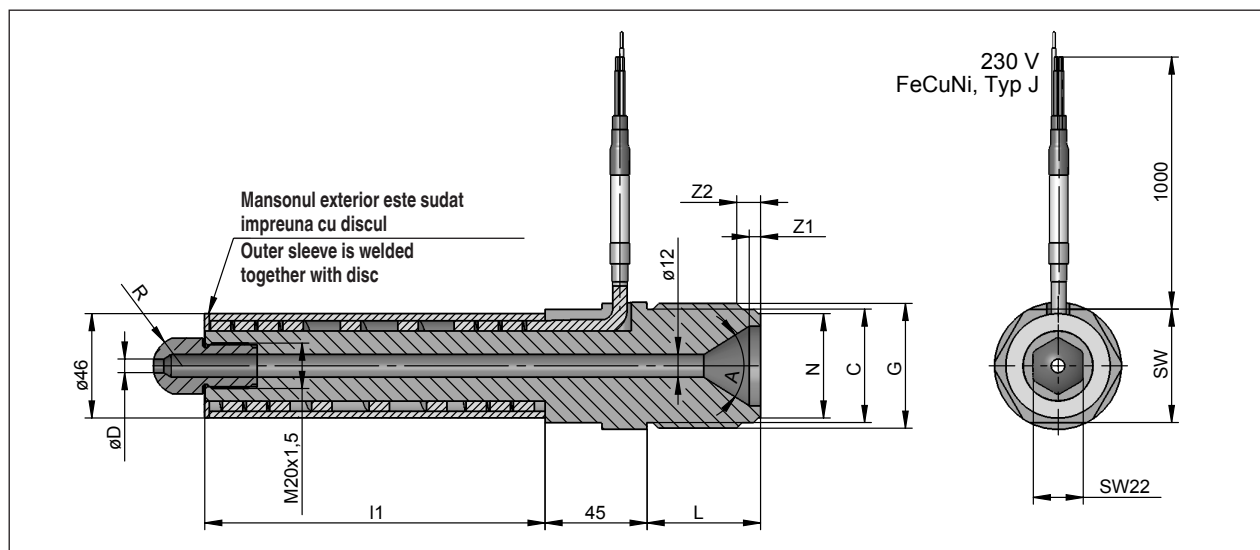

n	Nr. / No.	D [mm]	I1 [mm]	A [°]	C [mm]	G [mm]	L [mm]	N [mm]	Z1 [mm]	Z2 [mm]	R [mm]	SW [mm]
	S4630 /	X	X	X	X	X	X	X	X	X	X	X

Important:

Canalele unor materiale topite, trebuie sa treaca prin duza si varful duzei!

Alte tipuri de duze si varfuri de duze pot fi furnizate la cererea clientului.

Important:

Same melt material channel must run through nozzle body and tip!

Other nozzle designs or tips can be supplied on request.